



GENERAL

This CostGard™ Kit includes all non-standard components necessary for installation. It is designed for ducted air handlers, whether unitary or split. The kit provides flexibility for up-flow, downflow, and horizontal left or right applications. It replaces the p-trap on draw-through HVAC air handlers. Models 1525-71-56 and 1525-11-56 are suitable for HVAC units up to 30 tons with negative pressures in the drain pan compartment up to 1.5" w.c. The 1525-71-56 model works with a 3/4" drain, while the 1525-11-56 model is for a 1" drain. Both models require a minimum depth of 5.6" for proper installation, as well as enough depth for an adequately sloped drain line, typically 1/8" per foot.

Apart from the drain pan connection, two additional piping connections are required as shown in Figure 1. Point A should connect to the drain pan compartment, while the connection at point B must connect to the discharge side of the fan (supply plenum or supply duct). 1-3/8" and 1-5/8" hole saws are used to penetrate panels. Some HVAC manufacturers units that are "CostGard™ Ready" with penetrated panels.

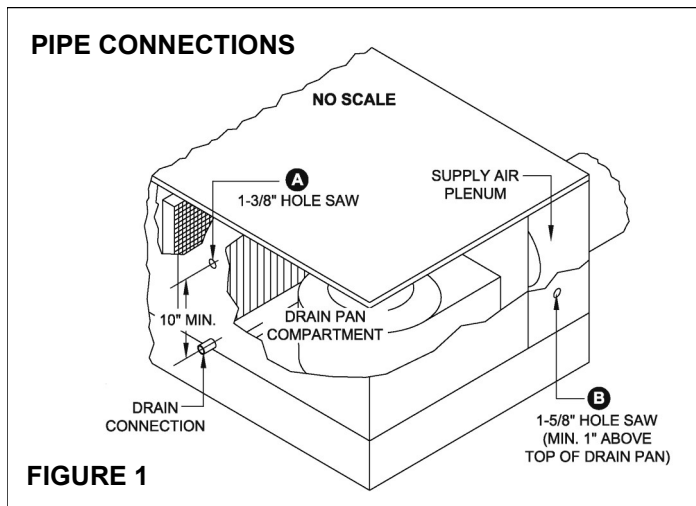

FIGURE 1

One of the primary requirements for a successful installation is routing all connecting pipes to avoid interference with service access panels. Before finalizing installation, drilling holes, cementing PVC connections, or securing supports, consider this requirement. Piping arrangements can vary greatly, and Figure 2 provides an example. More detailed drawings of possible installations for specific HVAC brands and models can be made available or prepared to simplify installation further. Contact Trent Technologies for any questions regarding this installation.

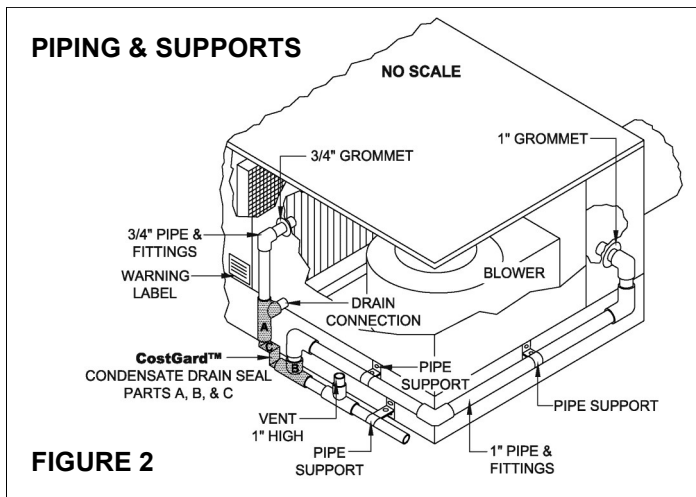

FIGURE 2

INSTALLATION

- STEP 1: Penetrate the side panel at point A (as shown in Figure 1) using a 1-3/8" hole saw. Insert the rubber grommet provided, and ensure that the hole is at least 10" above the condensate drain connection and open to the condensate drain pan compartment.
- STEP 2: Penetrate the side panel at point B (as shown in Figure 1) using a 1-5/8" hole saw. Insert the rubber grommet provided and ensure that the hole is at least 1" above the top of the condensate drain pan and open to the supply air plenum. Alternatively, point B can be moved to the supply duct.
- STEP 3: Install adapters as necessary to connect the PVC slip joint of the CostGard™ Condensate Drain Seal to the condensate drain pan connection.

CAUTION

TO PREVENT POSSIBLE DAMAGE TO INTERNAL COMPONENTS, EQUIP HOLE SAW WITH DEPTH STOP SUCH AS ILLUSTRATED BELOW.

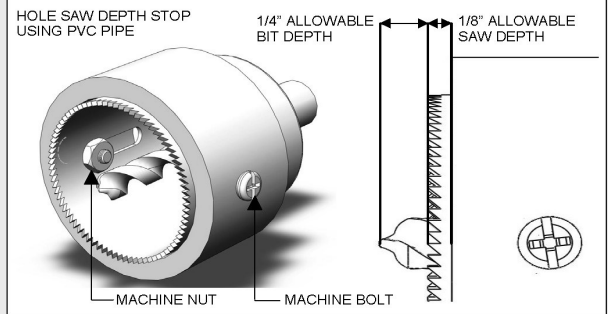

SUGGESTED HOLE SAW CONFIGURATION

GROMMET SIZE	HOLE SAW	PVC PIPE
3/4"	1-3/8"	1-1/4" SCH 40
1"	1-5/8"	1-1/2" SCH 40

- STEP 4: Identify the three (3) parts of the CostGard™ Condensate Drain Seal, designated as A, B & C, as shown below. Connect Part A to the drain pan connection as indicated in Figure 2. Ensure that the more extended segment of Part A is pointed downward and that the internally sloped end of Part C is inserted upward into the long port of Part A. Then connect Part B to Part C with the tee port pointing upward. Part B can be rotated up to 60° if necessary.

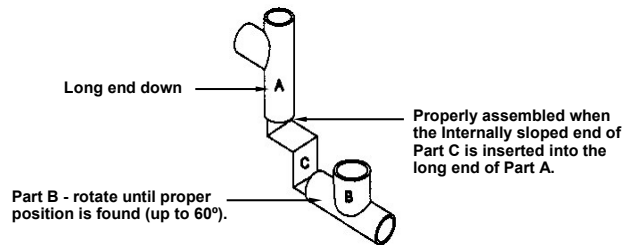

- STEP 5: Install 3/4" and 1" piping as indicated in Figure 2. The rubber grommets installed at points A and B provide airtight seals where the PVC pipes penetrate the respective side panels. All pipe connections must be firm and watertight. Use PVC cleaner and cement at ALL connections.
- STEP 6: Install support brackets on pipes as indicated in Figure 2.
- STEP 7: Attach the included informative yellow warning label.

NOTE: DO NOT CONNECT DRAIN PIPE DIRECTLY TO SANITARY SEWER. PROHIBITED BY PLUMBING CODES.



INSTALLATION NOTES

1. Before installing the CostGard™ Condensate Drain Seal on existing systems, ensure that the condensate drain pan and outlet port(s) are thoroughly cleaned and flushed to remove any accumulated algae, fungi, or debris.
2. The condensate drain line must be securely fixed in place and supported using pipe supports, as illustrated in Figure 2. This is essential to prevent excessive line movement that could damage the CostGard™ Condensate Drain Seal and connecting pipes. Also, the condensate drain line must not be less than 3/4" pipe size or 7/8" tubing size. The drain line must have a slope not less than 1/8" per foot, and it must be supported as necessary to ensure uniform drainage and that no condensate is trapped in the line.
3. In some installations, the CostGard™ Condensate Drain Seal and connecting piping may need to be insulated to prevent condensate formation on outside surfaces.
4. The CostGard™ Condensate Drain Seal models 1525-71-56 and 1525-11-56 can operate over a wide range of pressure conditions in the drain pan compartment and the supply air plenum (refer to Figure 3). However, in rare cases where the static pressure in the supply air plenum falls below the lower limit shown in Figure 3, it is still possible to use the CostGard™ Condensate Drain Seal. In such cases, you can obtain the required pressure level by installing a ram air scoop (a 90-degree elbow) on the air supply pipe and inserting it into the blower air stream until the desired pressure level is reached (refer to Figure 4a). Alternatively, you can use a unique scoop constructed as shown in Figure 4b.
5. For a few HVAC units where the blower static pressure rise exceeds the upper limit shown in Figure 3, it may still be possible to use the CostGard™ Condensate Drain Seal. In such cases, please contact Trent Technologies for a resolution.

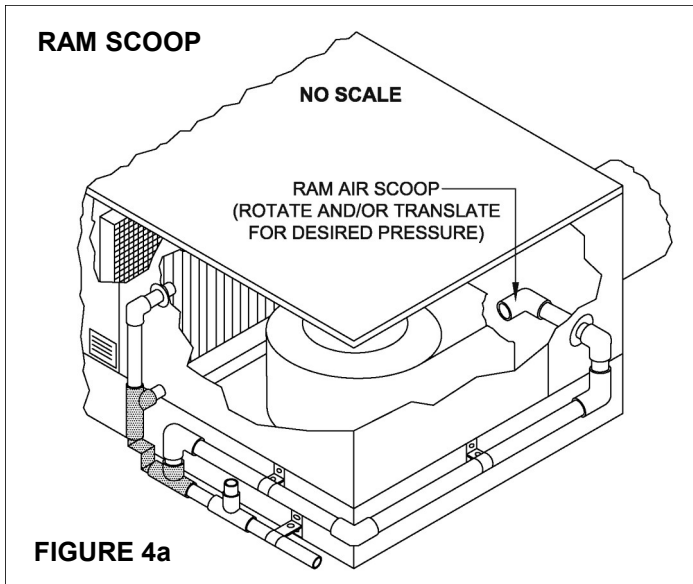

CHECKOUT PROCEDURES

With the system operating, take the following manometer measurements:

- 1) Static pressure in the drain pan compartment and,
- 2) Static pressure in the supply air plenum or supply duct.

If these pressure values fall within the "checkout range - air filter clean," defined in Figure 3, the system will operate properly. And it will operate properly when the filter is dirty and ready to be changed (.50" wc. pressure loss). During operation, a small quantity of air will be exhausted through the vent installed in the drain line pipe. If the measured pressures are not within the defined operating range, it may still be possible to use the CostGard™ Condensate Drain Seal models 1525-71-56 and 1525-11-56. For resolution, contact Trent Technologies.

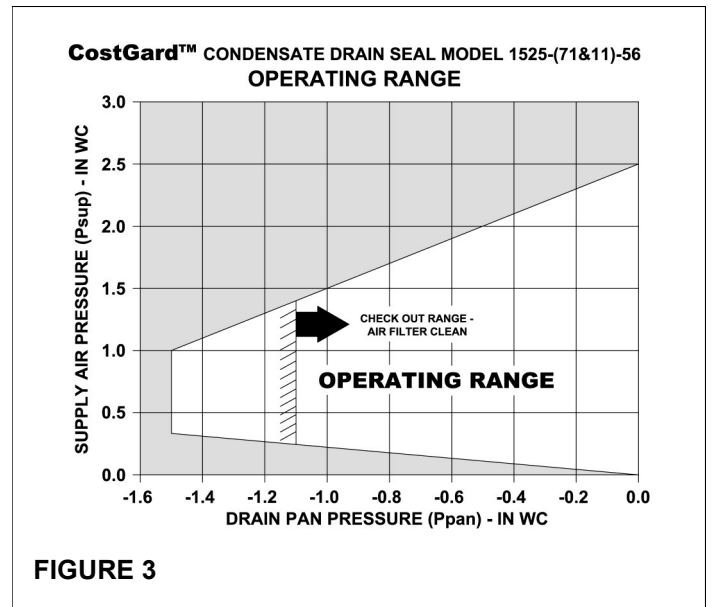

FIGURE 3

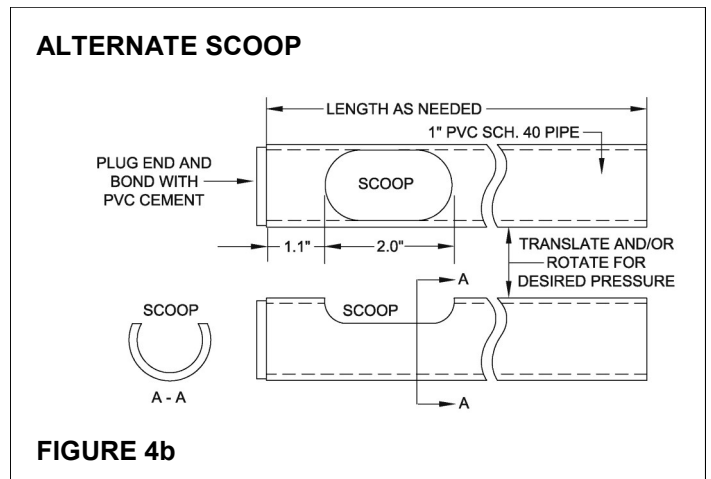

FIGURE 4b

NOTE: The CostGard™ Condensate Drain Seal design includes a unique self-cleaning, pulsing feature, which, like any active HVAC element (such as flowing air), produces an audible sound. This sound may be amplified and become objectionable in some above-ceiling and closet installation arrangements. In the unlikely event that this happens, contact *Trent Technologies* for resolution.